

HULTDINS SuperCut™

Features

- Designed for optimal balance.
- Automatic chain tension and proportional chain lubrication.
- Fast and easy bar and chain replacement.
- SuperCut minimizes stagnation time and enhances productivity.
- Simple carrier installation.

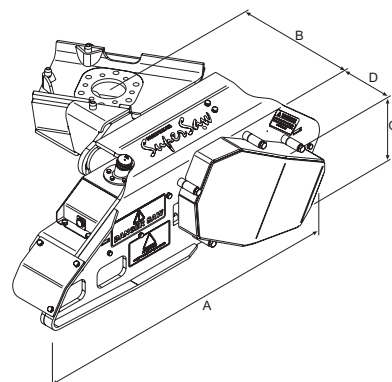

SuperSaw 650S

Saw motor displacement	cm ³	40
Weight	kg	370
Length "A"	mm	1397
Width "B"	mm	520
Height "C"	mm	511
Width "D"	mm	108
Min. hydraulic pressure, saw motor	MPa	20
Max. hydraulic pressure, saw motor	MPa	27
Min. flow, saw motor	l/min	200
Max. flow, saw motor	l/min	218
Saw chain		¾"
Saw bar	cm	100
Recommended grapples		SG 520S.

0109-7000608-EN